

**A displacement method
for the analysis of flexural shear stresses
in thin-walled isotropic composite beams**

W. Wagner, F. Gruttmann

Mitteilung 3(2002)

**A displacement method
for the analysis of flexural shear stresses
in thin-walled isotropic composite beams**

W. Wagner, F. Gruttmann

Mitteilung 3(2002)

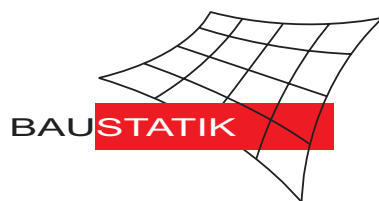

A displacement method for the analysis of flexural shear stresses in thin-walled isotropic composite beams

W. Wagner^a F. Gruttmann^b

^a Institut für Baustatik, Universität Karlsruhe (TH), Kaiserstraße 12, D-76131 Karlsruhe, Germany

^b Institut für Statik, Technische Universität Darmstadt, Alexanderstraße 7, D-64283 Darmstadt, Germany

Abstract

Shear stresses in cross-sections of prismatic beams can be evaluated for a given normal stress distribution by integration of the equilibrium equations. The considered thin-walled cross-sections have a constant thickness for each element and may be otherwise completely arbitrary. Introduction of a warping function yields a second order differential equation with constant coefficients. The solution of the boundary value problem leads to element stiffness relations for two-node-elements within a displacement method. The computed shear stresses are exact with respect to the underlying beam theory. It should be emphasized that the present formulation is especially suited for programming.

Keywords: Prismatic composite beams; Thin-walled cross-sections; Flexural shear stresses; Two-node element; Suitable for programming

1 Introduction

Shear stresses in prismatic beams subjected to bending without torsion can be evaluated using the equilibrium equations. The differential equation contains the transverse shear stresses and the normal stresses, see e.g. [1,2,3]. For arbitrary cross-sections one obtains a partial differential equation which can be solved approximately using the finite element method, e.g. [4,5]. In thin-walled cross-sections the flexural shear stresses are assumed to be constant through the thickness. For multiple connected cross-sections usually force methods are applied. The unknown circular shear flux for each cell is determined by continuity conditions. However the procedure is not convenient for programming. This holds especially for open profiles with intersections and for closed cross-sections.

In this paper we describe a displacement method which is well suited for programming. We consider straight beams subjected to torsionless bending. The shear stresses are obtained from a derivative of a warping function. Hence, the equilibrium leads to a second order ordinary differential equation with constant coefficients. The solution leads to stiffness matrices and load vectors for two-node elements within a displacement method. The computed solutions are exact within the underlying beam theory and satisfy the stress boundary conditions along free edges and the continuity conditions for multiple connected domains.

2 Torsionless bending of prismatic beams

We consider prismatic beams where the assumptions of the technical beam theory are given. Let x describe the length direction of the rod and y and z be section coordinates, which are not restricted to principal directions and lie arbitrarily with respect to the center of gravity S . The parallel system $\bar{y} = y - y_s$ and $\bar{z} = z - z_s$ intersects at S . The cross-section consists of m thin-walled elements and may be simply or multiple connected. Each element has a constant thickness h and α denotes the angle between the element and y -axis. Furthermore, we define a local coordinate s and specify the partial derivatives, denoted by commas

$$s = \sqrt{(\bar{y} - \bar{y}_1)^2 + (\bar{z} - \bar{z}_1)^2}, \quad s_{,y} = \cos \alpha, \quad s_{,z} = \sin \alpha. \quad (1)$$

Here \bar{y}_1, \bar{z}_1 are the boundary coordinates of the considered element. The beam is subjected to bending moments M_y and M_z and shear forces Q_y and Q_z . Further stress resultants are not present.

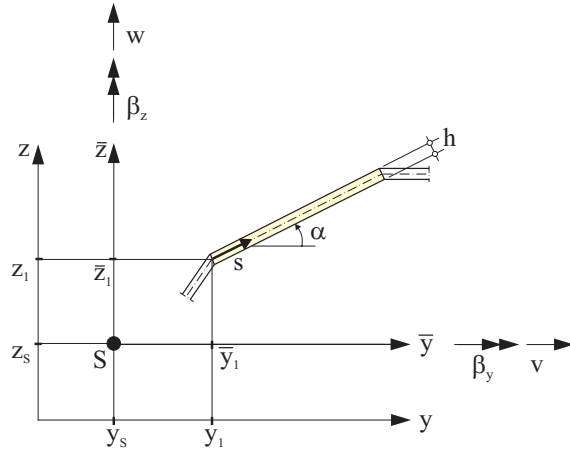

Fig. 1. Coordinate systems

Let $\beta_y(x)$ and $\beta_z(x)$ denote rotations about the axes y and z , and $v(x)$ and $w(x)$ the transverse displacements. Hence, the standard beam kinematic is extended by a warping function $\tilde{\varphi}(y, z)$ due to shear deformations, see also [4]:

$$\begin{aligned} u_x &= \beta_y(x) \bar{z} - \beta_z(x) \bar{y} + \tilde{\varphi}(y, z) \\ u_y &= v(x) \\ u_z &= w(x). \end{aligned} \quad (2)$$

The strains are obtained by partial derivatives as

$$\begin{aligned}
\varepsilon_x &= u_{x,x} &= \beta'_y \bar{z} - \beta'_z \bar{y} \\
\gamma_{xy} &= u_{x,y} + u_{y,x} &= -\beta_z + v' + \tilde{\varphi}_{,y} \\
\gamma_{xz} &= u_{x,z} + u_{z,x} &= \beta_y + w' + \tilde{\varphi}_{,z} ,
\end{aligned} \tag{3}$$

where the prime ($'$) describes the derivative with respect to the beam coordinate x .

The stresses follow from the material law for linear isotropic elasticity

$$\begin{aligned}
\sigma_x &= E_i \varepsilon_x = E_i (\beta'_y \bar{z} - \beta'_z \bar{y}) \\
\tau_{xy} &= G_i \gamma_{xy} = G_i (-\beta_z + v' + \tilde{\varphi}_{,y}) \\
\tau_{xz} &= G_i \gamma_{xz} = G_i (\beta_y + w' + \tilde{\varphi}_{,z}) ,
\end{aligned} \tag{4}$$

where E_i and G_i denote Young's modulus and shear modulus of element i , respectively. Further stress components σ_y , σ_z and τ_{yz} are set to zero within the beam theory.

Introducing the warping function φ with the substitutions

$$\varphi_{,y} = -\beta_z + v' + \tilde{\varphi}_{,y} \qquad \varphi_{,z} = \beta_y + w' + \tilde{\varphi}_{,z} , \tag{5}$$

applying the chain rule and using (1) yields

$$\begin{aligned}
\tau_{xy} &= G_i \varphi_{,y} = G_i \varphi_{,s} s_{,y} = \tau \cos \alpha \\
\tau_{xz} &= G_i \varphi_{,z} = G_i \varphi_{,s} s_{,z} = \tau \sin \alpha .
\end{aligned} \tag{6}$$

Here, $\tau(s)$ is the shear stress, which is constant through the thickness, and $t(s)$ is the shear flux

$$\tau(s) = G_i \varphi_{,s} \qquad t(s) = \tau h. \tag{7}$$

The equilibrium equations in terms of the beam stresses can be taken from the literature, e.g. [1]. Along free edges $s = s_a$ the shear stresses must vanish. Thus, the boundary value problem is defined as follows:

$$\begin{aligned}
\tau_{,s} + \sigma'_x &= G_i \varphi_{,ss} + \sigma'_x = 0 \\
\tau(s_a) &= 0
\end{aligned} \tag{8}$$

with

$$\sigma'_x = E_i (\beta''_y \bar{z} - \beta''_z \bar{y}) := n_i (a_y \bar{y} + a_z \bar{z}) . \tag{9}$$

where $n_i = E_i/E$ and E is a reference modulus.

The constants a_y and a_z are derived using the conditions

$$\begin{aligned} Q_y &= -M'_z = \int_{(A)} \sigma'_x \bar{y} \, dA \\ Q_z &= M'_y = \int_{(A)} \sigma'_x \bar{z} \, dA \end{aligned} \quad (10)$$

or with eq. (9)

$$\begin{aligned} Q_y &= \sum_{i=1}^m [n_i \int_{(A_i)} (a_y \bar{y}^2 + a_z \bar{y} \bar{z}) \, dA] \\ Q_z &= \sum_{i=1}^m [n_i \int_{(A_i)} (a_z \bar{z}^2 + a_y \bar{y} \bar{z}) \, dA], \end{aligned} \quad (11)$$

where A_i denotes the area of the element section. Introducing the moments of inertia

$$I_{\bar{y}}^n = \sum_{i=1}^m [n_i \int_{(A_i)} \bar{z}^2 \, dA], \quad I_{\bar{z}}^n = \sum_{i=1}^m [n_i \int_{(A_i)} \bar{y}^2 \, dA], \quad I_{\bar{y}\bar{z}}^n = \sum_{i=1}^m [n_i \int_{(A_i)} \bar{y} \bar{z} \, dA], \quad (12)$$

the system of equations (11) can be solved for the unknown parameters a_y und a_z

$$a_y = \frac{Q_y I_{\bar{y}}^n - Q_z I_{\bar{y}\bar{z}}^n}{I_{\bar{y}}^n I_{\bar{z}}^n - I_{\bar{y}\bar{z}}^n I_{\bar{y}\bar{z}}^n}, \quad a_z = \frac{Q_z I_{\bar{z}}^n - Q_y I_{\bar{y}\bar{z}}^n}{I_{\bar{y}}^n I_{\bar{z}}^n - I_{\bar{y}\bar{z}}^n I_{\bar{y}\bar{z}}^n}. \quad (13)$$

The integral of the shear stresses (6) yields the shear forces, thus it holds $Q_y = \int_{(A)} \tau_{xy} \, dA$ and $Q_z = \int_{(A)} \tau_{xz} \, dA$. The proof is given in the appendix.

3 The displacement method

The cross-section is discretized with m two-node elements, see Fig. 2. The nodes must be positioned only at the element intersections, at free edges and at thickness jumps. The element coordinates are $\mathbf{r}_1 = \{y_1, z_1\}$, $\mathbf{r}_2 = \{y_2, z_2\}$, the length is denoted by l and the thickness h is constant for each element. Furthermore, we introduce the local normalized coordinate $0 \leq \xi = s/l \leq 1$.

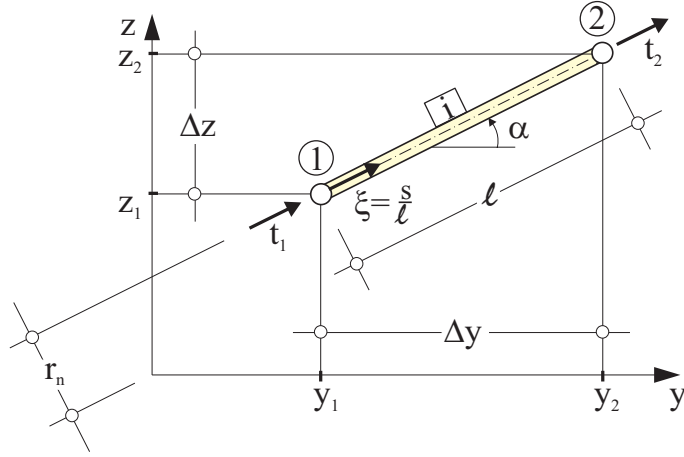

Fig. 2. Two-node element

The linear inhomogeneous second order differential equation (8)₁ can be solved exactly as

$$\begin{aligned} \varphi &= \varphi_h + \varphi_p & \varphi_h &= c_1 + c_2 \xi & (14) \\ & & \varphi_p &= c_3 \xi^2 + c_4 \xi^3. \end{aligned}$$

The constants c_3 and c_4 of the particular solution are obtained with

$$\begin{aligned} \bar{y} &= \bar{y}_1 + \Delta y \xi & \bar{y}_1 &= y_1 - y_s & \Delta y &= y_2 - y_1 \\ \bar{z} &= \bar{z}_1 + \Delta z \xi & \bar{z}_1 &= z_1 - z_s & \Delta z &= z_2 - z_1 \end{aligned} \quad (15)$$

as

$$c_3 = -\frac{l^2}{2G_i} n_i (a_y \bar{y}_1 + a_z \bar{z}_1) \quad c_4 = -\frac{l^2}{6G_i} n_i (a_y \Delta y + a_z \Delta z). \quad (16)$$

The constants c_1 and c_2 are replaced using the element degrees of freedom $\varphi_1 = \varphi(0)$ and $\varphi_2 = \varphi(1)$

$$c_1 = \varphi_1 \quad c_2 = \varphi_2 - \varphi_1 - c_3 - c_4. \quad (17)$$

Hence, the shear flux $t(\xi)$ is derived with (7) and (14)

$$t(\xi) = G_i h \varphi_{,s} = \frac{G_i h}{l} (c_2 + 2c_3 \xi + 3c_4 \xi^2). \quad (18)$$

Evaluation of $t(\xi)$ at $\xi = 0$ and $\xi = 1$ yields with (17) the nodal values $t_1 = -t(0)$ and $t_2 = t(1)$

$$\begin{bmatrix} t_1 \\ t_2 \end{bmatrix} = \frac{G_i h}{l} \begin{bmatrix} 1 & -1 \\ -1 & 1 \end{bmatrix} \begin{bmatrix} \varphi_1 \\ \varphi_2 \end{bmatrix} - \frac{G_i h}{l} \begin{bmatrix} -c_3 & -c_4 \\ -c_3 & -2c_4 \end{bmatrix} \quad (19)$$

$$\mathbf{t}_i = \mathbf{k}_i \mathbf{v}_i - \mathbf{f}_i.$$

Introducing the element node matrix \mathbf{a}_i which relates the element arrays to the global arrays one obtains

$$\bar{\mathbf{v}}_i = \mathbf{a}_i \mathbf{V} \quad \mathbf{T}_i = \mathbf{a}_i^T \mathbf{t}_i. \quad (20)$$

The number of components of \mathbf{V} corresponds to the number of nodes. Furthermore, \mathbf{T}_i denotes the global shear flux vector of element i . The equilibrium in length direction requires that the sum of the shear fluxes must vanish at the nodes. Considering (19) and (20) one obtains

$$\sum_{i=1}^m \mathbf{T}_i = \mathbf{K} \mathbf{V} - \mathbf{F} = \mathbf{0}. \quad (21)$$

The global stiffness matrix \mathbf{K} and the right hand side vector \mathbf{F} are obtained by standard assembly procedures

$$\mathbf{K} = \sum_{i=1}^m \mathbf{a}_i^T \mathbf{k}_i \mathbf{a}_i \quad \mathbf{F} = \sum_{i=1}^m \mathbf{a}_i^T \mathbf{f}_i. \quad (22)$$

The system of equations (21) can be solved with $V_I = 0$ where I is an arbitrary node. A different node yields another solution for \mathbf{V} which distinguishes only by a constant. This describes a rigid body motion, which has no influence on the shear stresses.

The back substitution yields with (18) the shear flux and with $\tau(\xi) = t(\xi)/h$ the shear stresses for every element. Furthermore, we introduce the unit warping function with $\int_{(A)} \bar{\varphi} \, dA = 0$ by

$$\bar{\varphi} = \varphi - \frac{1}{A} \int_{(A)} \varphi \, dA, \quad (23)$$

where $A = \sum_{i=1}^m A_i$. The integral can be computed by a summation over the elements as follows

$$\int_{(A)} \varphi \, dA = \sum_{i=1}^m \left[hl \left(c_1 + \frac{1}{2}c_2 + \frac{1}{3}c_3 + \frac{1}{4}c_4 \right) \right]_i. \quad (24)$$

Thus, the arbitrary nodal point I with $V_I = 0$ does not influence the result for $\bar{\varphi}$. For symmetric

cross-sections symmetry conditions for $\bar{\varphi}$ can be considered to reduce the total number of unknowns. Finally the function φ is specified with (5)

$$\varphi(y, z) = (-\beta_z + v') \bar{y} + (\beta_y + w') \bar{z} + \tilde{\varphi}(y, z). \quad (25)$$

Note, that $\tilde{\varphi}$ describes the nonlinear part of the warping function and the derivative of $\tilde{\varphi}$ the nonlinear part of the shear stresses.

4 Center of shear

For the center of shear M with coordinates $\{y_M, z_M\}$ the condition holds

$$Q_z y_M - Q_y z_M = \int_{(A)} (\tau_{xz} y - \tau_{xy} z) dA = \int_{(A)} \tau (y \sin \alpha - z \cos \alpha) dA, \quad (26)$$

with the flexural shear stresses according to (6). The integration yields

$$\int_{(A)} \tau y \sin \alpha dA = \sum_{i=1}^m G_i \left[h \sin \alpha \{ y_1 (c_2 + c_3 + c_4) + \Delta y (\frac{1}{2} c_2 + \frac{2}{3} c_3 + \frac{3}{4} c_4) \} \right]_i \quad (27)$$

and corresponding expressions for $\int_{(A)} \tau z \cos \alpha dA$. To determine y_M a computation with $Q_y = 0$ and $Q_z = 1$ has to be carried out and properly for z_M .

Using Betty–Maxwell reciprocal relations Weber [6] showed, that the coordinates of the center of shear and of the center of twist are identical, the latter being defined as point of rest in a cross-section of a twisted beam. Based on this result explicit formulae for y_M and z_M can be derived

$$y_M = -\frac{R_y^n I_z^n - R_z^n I_y^n}{I_y^n I_z^n - I_{yz}^n I_{yz}^n} \quad z_M = \frac{R_z^n I_y^n - R_y^n I_z^n}{I_y^n I_z^n - I_{yz}^n I_{yz}^n}. \quad (28)$$

The proof is given in the appendix. In the following the so-called warping moments using the warping function $\omega(y, z)$ of the Saint–Venant torsion theory are specified:

$$R_y^n := \sum_{i=1}^m [n_i \int_{(A_i)} \omega \bar{z} dA], \quad R_z^n := \sum_{i=1}^m [n_i \int_{(A_i)} \omega \bar{y} dA]. \quad (29)$$

For this purpose the Saint-Venant torsion stresses are expressed with the derivatives of $\omega(y, z)$ and the twist θ , e.g. [1]

$$\begin{aligned} \tilde{\tau}_{xy} &= G_i \theta (\omega_{,y} - z) = \tilde{\tau} \cos \alpha \\ \tilde{\tau}_{xz} &= G_i \theta (\omega_{,z} + y) = \tilde{\tau} \sin \alpha. \end{aligned} \quad (30)$$

We use the tilde to distinguish the torsion quantities from the bending quantities. The shear stresses $\tilde{\tau}(s)$ and the flux $\tilde{t}(s)$ follow from

$$\tilde{\tau}(s) = G_i \theta (\omega_{,s} - r_n), \quad \tilde{t}(s) = \tilde{\tau} h. \quad (31)$$

The element coordinates y, z can be written as $y = -r_n \sin \alpha$ and $z = r_n \cos \alpha$ where the orthogonal distance r_n is expressed with the element coordinates, see Fig. 2

$$r_n = \text{sign}(z_n \Delta y - y_n \Delta z) |\mathbf{r}_n| \quad \text{with} \quad \mathbf{r}_n = \{y_n, z_n\} \quad (32)$$

$$\mathbf{r}_n = \mathbf{r}_1 + \xi_n \mathbf{n}, \quad \xi_n = -\mathbf{r}_1 \cdot \mathbf{n}, \quad \mathbf{n} = (\mathbf{r}_2 - \mathbf{r}_1)/l.$$

The equilibrium in length direction with $\sigma_x \equiv 0$ and stress boundary conditions of the Saint–Venant torsion theory read

$$\tilde{\tau}_{,s} = G_i \theta \omega_{,ss} = 0 \quad \tilde{\tau}(s_a) = 0. \quad (33)$$

The solution of the differential equation reads $\omega(\xi) = \tilde{c}_1 + \tilde{c}_2 \xi$. The constants are expressed through the element degrees of freedom $\omega_1 = \omega(0)$ and $\omega_2 = \omega(1)$ as $\tilde{c}_1 = \omega_1$ und $\tilde{c}_2 = \omega_2 - \omega_1$. From (31)₂ and with a linear shape of ω we observe, that $\tilde{t}(s)$ is constant in each element. With boundary condition (33)₂, $\tilde{t} \equiv 0$ holds for open parts of the cross–section and thus only closed parts of the cross–section contribute to the torsion moment.

Evaluation of (31)₂ yields the shear flux at the nodes $\tilde{t}_1 = -\tilde{t}(0)$ and $\tilde{t}_2 = \tilde{t}(1)$

$$\begin{bmatrix} \tilde{t}_1 \\ \tilde{t}_2 \end{bmatrix} = \theta \left\{ \frac{G_i h}{l} \begin{bmatrix} 1 & -1 \\ -1 & 1 \end{bmatrix} \begin{bmatrix} \omega_1 \\ \omega_2 \end{bmatrix} - G_i h \begin{bmatrix} -r_n \\ r_n \end{bmatrix} \right\} \quad (34)$$

$$\tilde{\mathbf{t}}_i = \tilde{\mathbf{k}}_i \tilde{\mathbf{v}}_i - \tilde{\mathbf{f}}_i.$$

For the assembly $\theta = 1$ can be set. The assembly and the solution of the system of equations is described in (20) - (22).

The unit warping function is defined as $\bar{\omega} = \omega - \int_{(A)} \omega \, dA/A$. Having $\omega(s)$ we are able to express the warping moments as

$$R_{\bar{z}}^n = \sum_{i=1}^m n_i \left[h l \left\{ \bar{y}_1 (\tilde{c}_1 + \frac{1}{2} \tilde{c}_2) + \Delta y \left(\frac{1}{2} \tilde{c}_1 + \frac{1}{3} \tilde{c}_2 \right) \right\} \right]_i \quad (35)$$

and corresponding expression for $R_{\bar{y}}^n$. Thus evaluating eq. (28), both coordinates can be calculated in one step.

Remark:

An alternative direct method for the evaluation of warping properties due to torsion ($y_M, z_M, F_{\omega\omega} = \int \omega^2 dA$) of thin-walled open and closed profiles has been given in [8]. Their theory for open profiles requires two modifications before it can be applied to closed profiles. For each cell of the profile the evaluation of a constant Ψ is necessary. Secondly one has to omit one element from each cell for the element equations whereas this is not the case for the property equations, see [8]. Furthermore the global system of equations is non-symmetric.

5 Examples

The first three examples deal with constant Young's modulus and shear modulus. Within the fourth example we consider a composite cross-section.

5.1 Open cross-section

The first example is taken from the textbook of Petersen [2]. The welded profile consisting of a U300 (DIN 1026) and L160 × 80 × 12 (DIN 1029) is replaced by a thin-walled cross-section, see Fig. 3. The discretization is performed with 5 elements and 6 nodes. The local coordinate s follows from the element node relations. For this example a system of equations with 5 unknowns has to be solved. We calculate the shear stresses due to $Q_y = -120$ kN and $Q_z = -200$ kN, see Fig. 4. The results are exact within the underlying beam theory and correspond to the solution in [2], which is computed by hand. The coordinates of the center of shear are evaluated using eq. (26) or (28). The warping function $\bar{\varphi}$ with $G = 1$ kN/cm² is depicted in Fig. 5. One can see, that the nonlinear part of $\bar{\varphi}$ in comparison to the linear part is small, see also eq. (25).

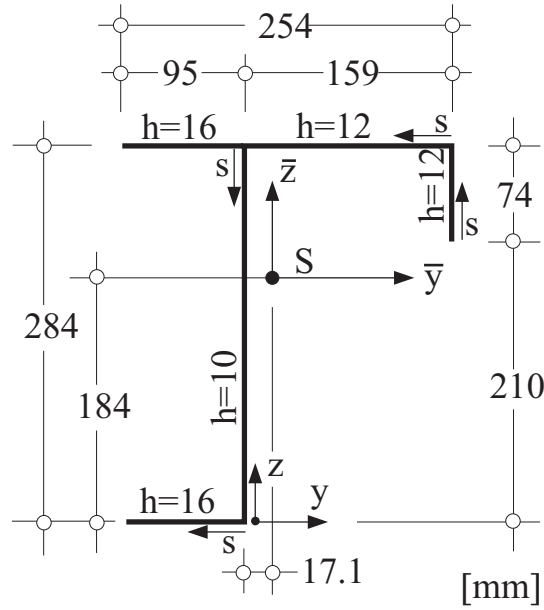

$$\begin{aligned}
 A &= 86.76 \text{ cm}^2 \\
 I_{\bar{y}} &= 11376.92 \text{ cm}^4 \\
 I_{\bar{z}} &= 4513.26 \text{ cm}^4 \\
 I_{\bar{y}\bar{z}} &= 3013.22 \text{ cm}^4 \\
 \bar{y}_M &= 1.386 \text{ cm} \\
 \bar{z}_M &= 10.058 \text{ cm}
 \end{aligned}$$

Fig. 3. Open cross-section

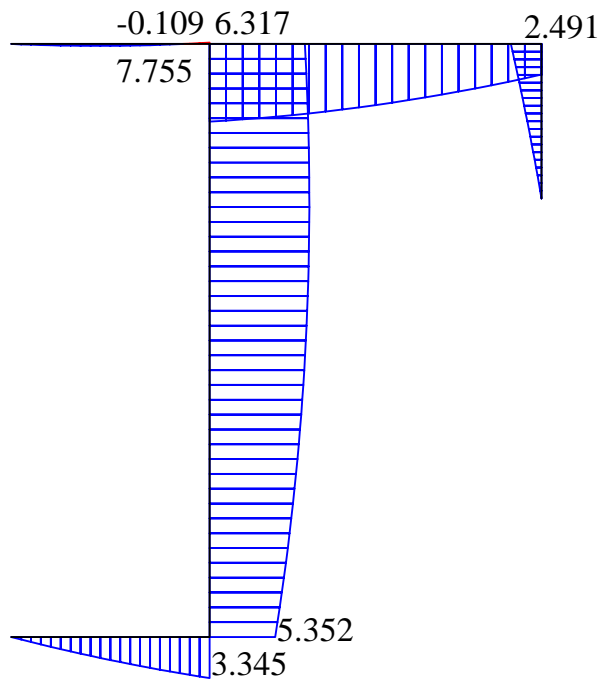

Fig. 4. Shear stresses $\tau(s)$ in kN/cm^2

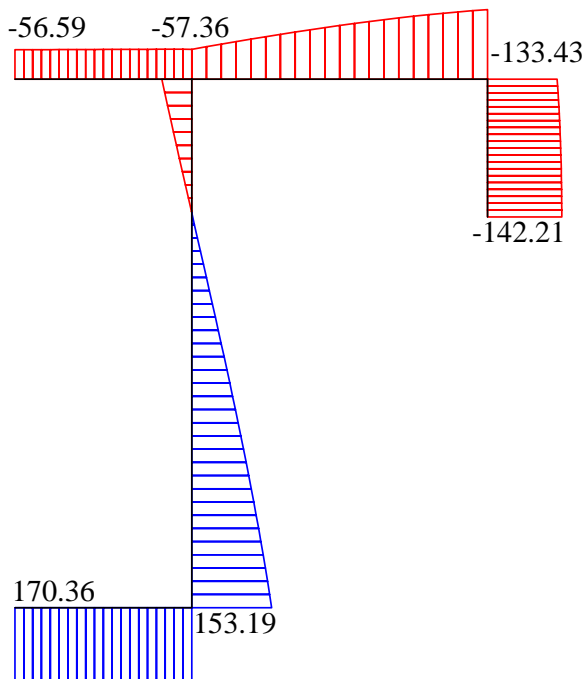

Fig. 5. Warping function $\bar{\varphi}$ in cm

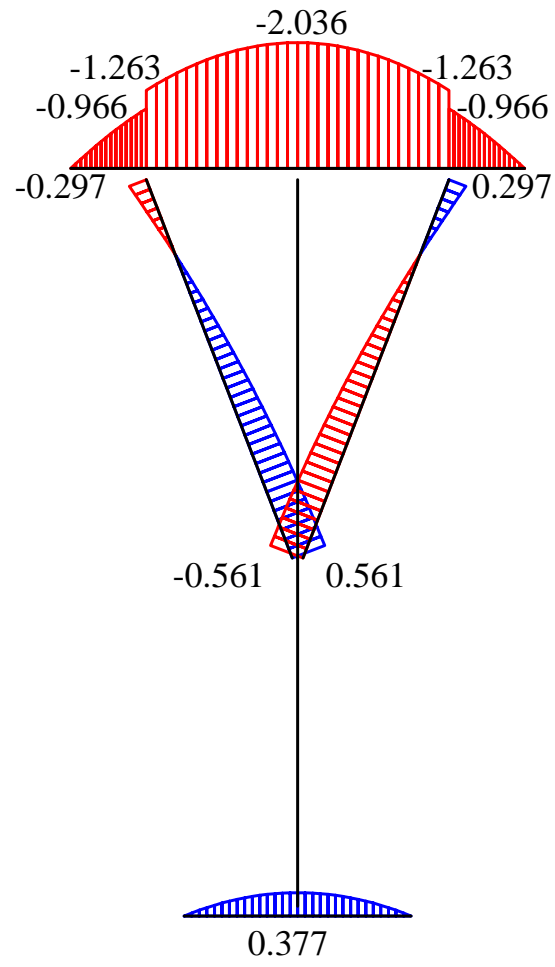

Fig. 7. Shear flux due to Q_y in kN/cm

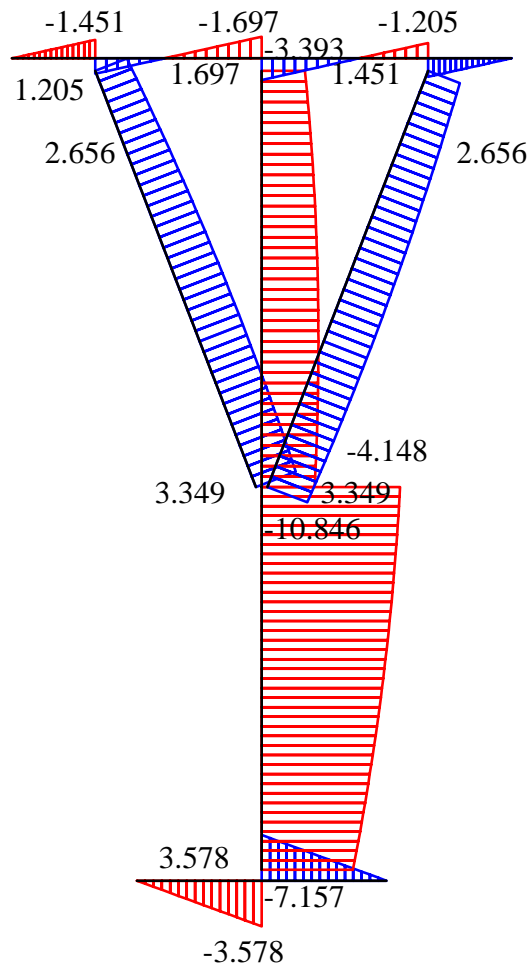
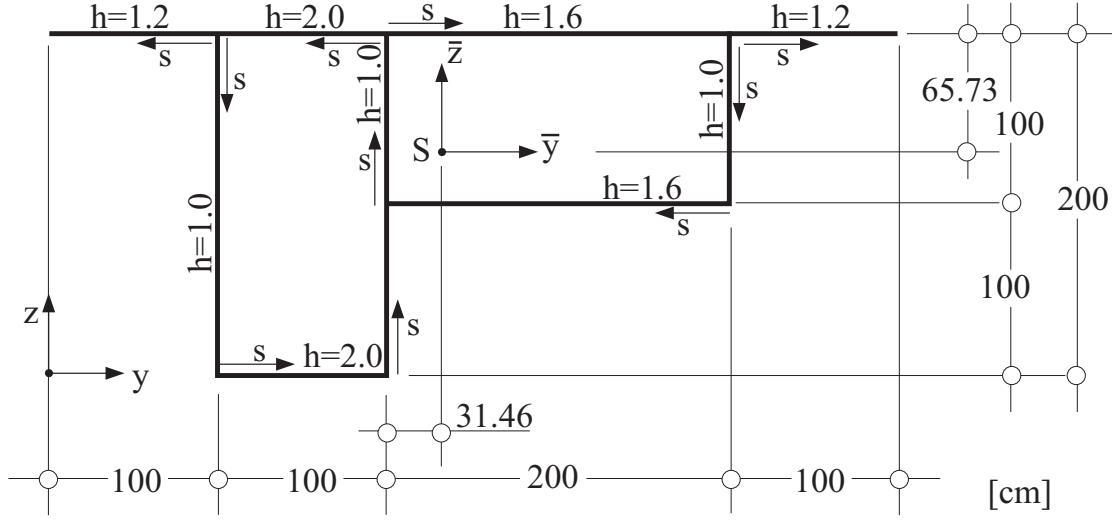

Fig. 8. Shear flux due to Q_z in kN/cm

5.3 Cross-section with two cells

The third example according to Fig. 9 is also taken from [2]. The considered profile is unsymmetrical and has open and closed parts with two cells. We use 9 nodes and 10 elements for a discretization. The coordinates of the center of shear are evaluated with eq. (26) or (28), respectively. Fig. 10 shows the computed shear stresses due to $Q_z = -1000$ kN. The values at $\bar{z} = 0$ in the webs are given. Again, the solution is exact and corresponds to the results in [2], which are calculated by hand. The warping function $\bar{\varphi}$ for $G = 1$ kN/cm² is depicted in Fig. 11. As the plot shows there is continuity of the displacement field within the whole domain.



$A = 1780.0 \text{ cm}^2$	$I_{\bar{y}} = 9176217.2 \text{ cm}^4$
$\bar{y}_M = -35.144 \text{ cm}$	$I_{\bar{z}} = 24504869 \text{ cm}^4$
$\bar{z}_M = 19.614 \text{ cm}$	$I_{\bar{y}\bar{z}} = 3480898.9 \text{ cm}^4$

Fig. 9. Cross section with two cells

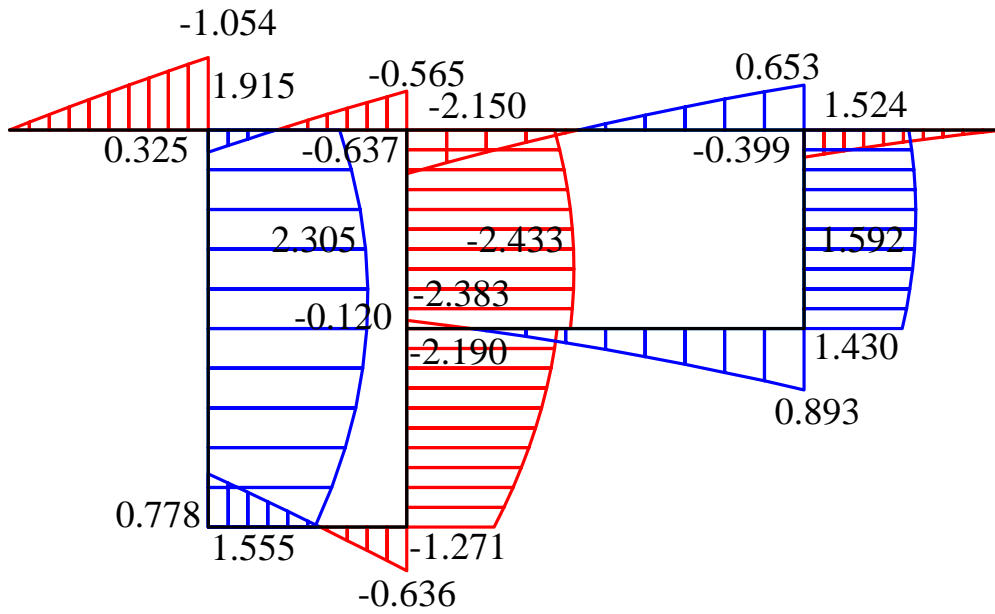

Fig. 10. Shear stresses $\tau(s)$ in kN/cm^2

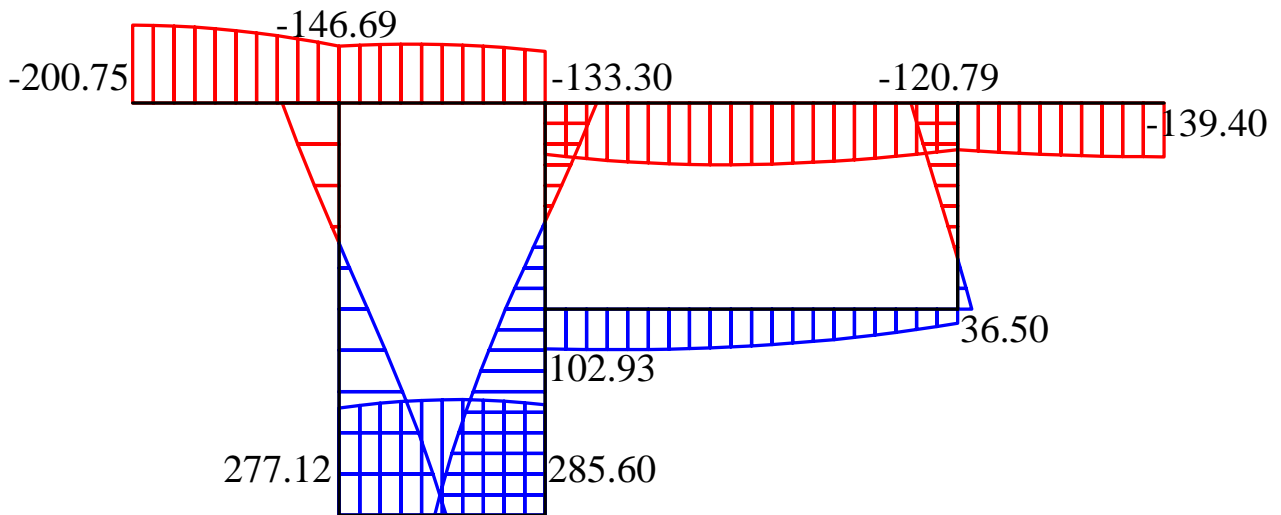

Fig. 11. Warping function $\bar{\varphi}$ in cm

5.4 Composite cross-section

The composite cross-section according to Fig. 12 consists of a concrete part and a steel part, see [3]. The ratio of Young's modules and shear modules is $E_s/E_c = 5.7$ and $G_s/G_c = 5.4$. As reference modulus we choose $E = E_s$. To avoid overlapping of the web with the flange a gap with $l = 12.5$ cm and vanishing thickness h has been introduced in [3], see Fig. 12. Without considering symmetry the cross-section is discretized with 8 nodes and 6 elements. The nodes across the gaps are assumed to have the same warping ordinate which is enforced when solving the global system of equations. The shear force is given as $Q_y = -3732309.9$ kN, thus we obtain a constant $a_y = -1$. The coordinates of the center of shear are evaluated with eq. (26) or (28), respectively. Due to symmetry $y_M = 0$ holds. The computed shear flux corresponds to the solution in [3], see Fig. 13. The warping function is depicted in Fig. 14.

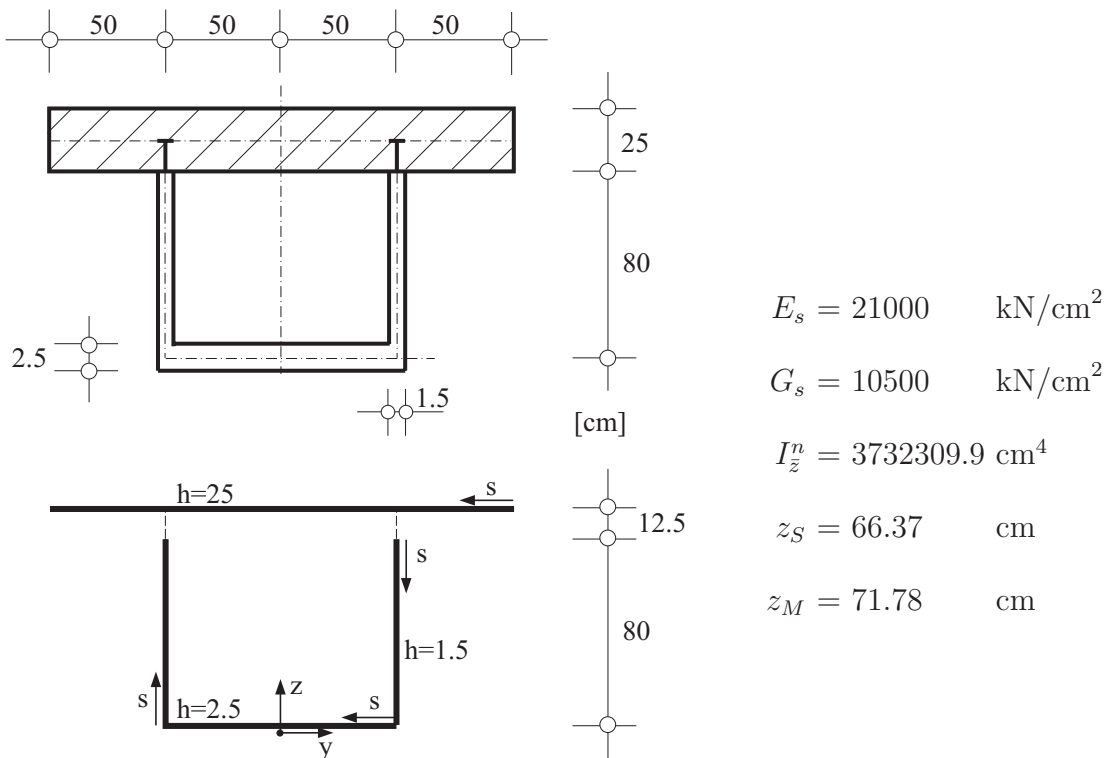

Fig. 12. Composite cross-section

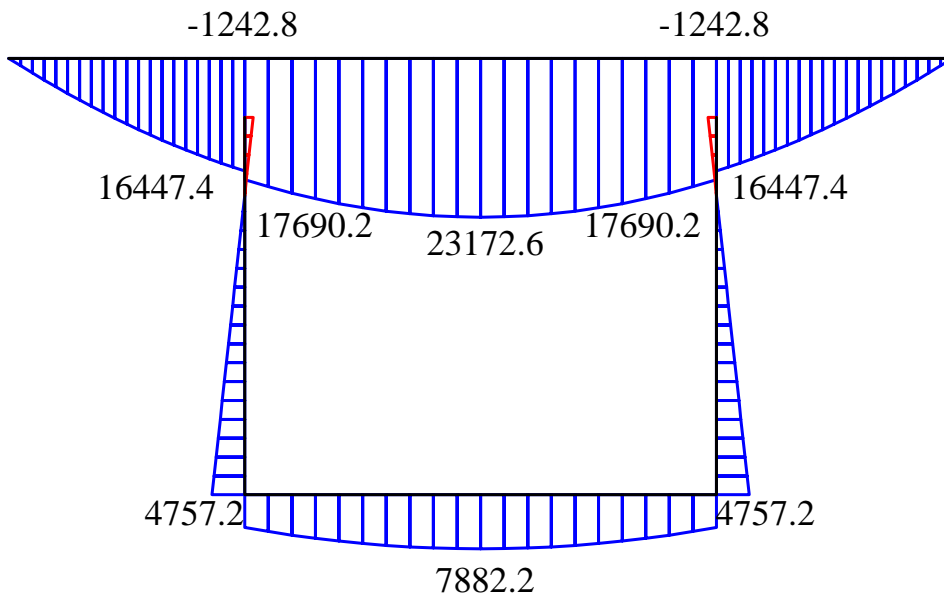

Fig. 13. Shear flux $t(s)$ in kN/cm

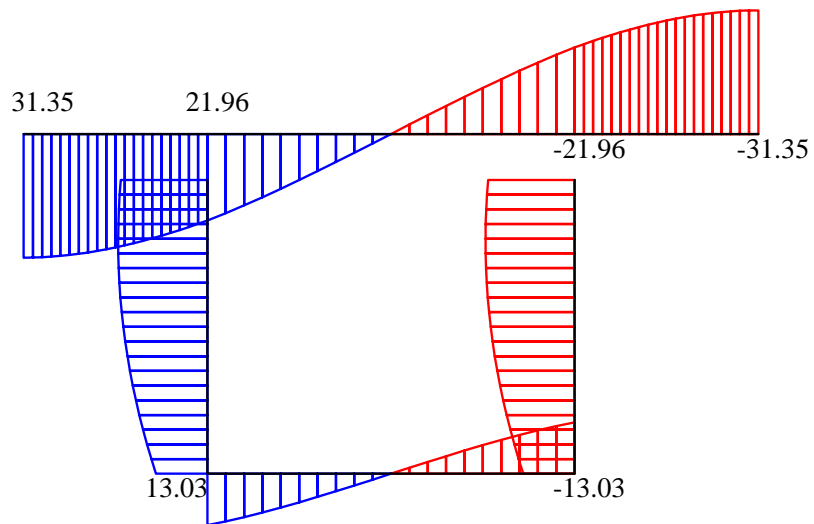

Fig. 14. Warping function $\bar{\varphi}$ in cm

6 Conclusions

For the numerical analysis of the shear stresses in cross-sections of prismatic beams a displacement method has been developed. The approach holds for arbitrary open and closed thin-walled profiles. The discretizations are performed using two-node elements. The computed shear stresses are exact within the underlying beam theory. The stress boundary conditions along free edges and the continuity conditions for multiple connected domains are automatically fulfilled. Furthermore the procedure yields the coordinates of the center of shear. The essential equations can easily be implemented in a finite element program. Several examples show the correctness of the implementation.

A Appendix

A.1 Integral of the shear stresses

The integral of τ_{xy} according to (6)₁ is reformulated adding the equilibrium equations (8)₁

$$\int_{(A)} \tau_{xy} dA = \int_{(s)} [\tau \cos \alpha + \bar{y} (\tau_{,s} + \sigma'_x)] h ds. \quad (\text{A.1})$$

With $\bar{y} = \bar{y}_1 + s \cos \alpha$ and thus $\bar{y}_{,s} = \cos \alpha$ it holds

$$\int_{(A)} \tau_{xy} dA = \int_{(s)} [(\tau \bar{y})_{,s} + \sigma'_x \bar{y}] h ds \quad (\text{A.2})$$

and with integration by parts

$$\int_{(A)} \tau_{xy} dA = - \int_{(s)} (\tau \bar{y} h_{,s}) ds + [(\tau \bar{y}) h]_{s_a}^{s_b} + \int_{(s)} \sigma'_x \bar{y} dA. \quad (\text{A.3})$$

The first integral of the right hand side vanishes with constant thickness h . This, also holds for the boundary term considering (8)₂. Therefore eq. (A.3) yields with (10)₁ the shear force Q_y . In an analogous way one can show that integration of τ_{xz} according to (6)₂ yields Q_z .

A.2 Coordinates of the center of shear

In order to derive explicit formulae for y_M, z_M we introduce the stress function Φ and the warping function ω of the Saint-Venant torsion theory [1] by

$$\Phi_{,z} = \omega_{,y} - z \quad - \Phi_{,y} = \omega_{,z} + y \quad (\text{A.4})$$

where ω is solution of the boundary value problem (33). Now, eq. (26) can be reformulated inserting y and z from (A.4)

$$Q_z y_M - Q_y z_M = \int_{(A)} \tau [(-\Phi_{,y} - \omega_{,z}) \sin \alpha - (-\Phi_{,z} + \omega_{,y}) \cos \alpha] dA \quad (\text{A.5})$$

and with application of the chain rule and eq. (1)

$$\begin{aligned} Q_z y_M - Q_y z_M &= \int_{(A)} \tau [\Phi_{,s} (\sin \alpha \cos \alpha - \sin \alpha \cos \alpha) - \omega_{,s} (\sin^2 \alpha + \cos^2 \alpha)] dA \\ &= - \int_{(A)} \tau \omega_{,s} dA. \end{aligned} \quad (\text{A.6})$$

Integration by parts leads to

$$Q_z y_M - Q_y z_M = \int_{(A)} \tau_{,s} \omega dA - [\tau \omega h]_{s_a}^{s_b}. \quad (\text{A.7})$$

The boundary term vanishes considering (8)₂. Inserting (8)₁ and (9) it holds

$$Q_z y_M - Q_y z_M = - \sum_{i=1}^m \left[\int_{(A_i)} n_i (a_y \bar{y} + a_z \bar{z}) \omega dA \right]. \quad (\text{A.8})$$

Introducing the warping moments according to (29) we get

$$Q_z y_M - Q_y z_M = -a_y R_{\bar{z}}^n - a_z R_{\bar{y}}^n. \quad (\text{A.9})$$

Inserting (13), with $Q_y = 0$ one obtains y_M and with $Q_z = 0$ the coordinate z_M according to (28) is given. For a homogeneous beam cross-section and assuming principal axes the corresponding formulas have been derived by Trefftz [7] using an energy criterion.

References

- [1] Timoshenko SP, Goodier JN. Theory of Elasticity. London: McGraw-Hill; 1984. 1, 2, 4, A.2
- [2] Petersen C. Stahlbau. Braunschweig, Wiesbaden: Vieweg-Verlag; 1988. 1, 5.1, 5.2, 5.3
- [3] Friemann H. Schub und Torsion in geraden Stäben. 2. Auflage. Düsseldorf: Werner-Verlag; 1993. 1, 5.4
- [4] Gruttmann F, Wagner W, Sauer R. Zur Berechnung der Schubspannungen aus Querkräften in Querschnitten prismatischer Stäbe mit der Methode der finiten Elemente. Bauingenieur 1998;73(11):485-490. 1, 2

- [5] Gruttmann F, Wagner W. Shear correction factors in Timoshenko's beam theory for arbitrary cross-sections. Computational Mechanics 2001;27:199–207. [1](#)
- [6] Weber C. Übertragung des Drehmoments in Balken mit doppelflanschigem Querschnitt. ZAMM 1926;6:85–97. [4](#)
- [7] Trefftz E. Über den Schubmittelpunkt in einem durch eine Einzellast gebogenen Balken. ZAMM 1935;15:220–225. [A.2](#)
- [8] Murray, N.W., Attard M.M. A Direct Method of Evaluating the Warping Properties of Thin-Walled Open and Closed Profiles Thin-Walled Structures 1987;351–364. [4](#)